

Technical Data

CUT 20 P, CUT 30 P

		CUT 20 P	CUT 30 P
Mechanical body			
Machine dimensions *	mm	2500 x 2500 x 2200	3100 x 2800 x 2325
	in	98.5 x 98.5 x 86.6	122 x 11.2 x 91.5
Machine floor space **	mm (in)	3500 x 3500 (137.8 x 137.8)	4000 x 4000 (157.5 x 157.5)
Machine weight (Without dielectric)	kg (lbs)	3000 (6613)	5000 (11023)
Work zone			
Max. inside dimensions *	mm (in)	1050 x 765 x 560 (41.3 x 30.1 x 22)	1260 x 945 x 675 (49.60 x 37.20 x 26.57)
Maximum workpiece size *	mm	900 x 680 x 250	1050 x 800 x 350
	in	33.43 x 26.77 x 9.84	41.30 x 31.50 x 13.75
Maximum workpiece weight	kg (lbs)	400 (882)	1000 (2204)
Table size	mm (in)	700 x 480 (27.55 x 18.89)	950 x 630 (37.4 x 24.80)
Angle of tank door	°	180	180
Distance between table surface and floor	mm (in)	1050 (41.33)	1060 (41.70)
Axis			
Travel X, Y, Z	mm (in)	350 x 250 x 250 (13.78 x 9.84 x 9.84)	600 x 400 x 350 (23.60 x 15.70 x 13.75)
Travel U, V	mm (in)	± 45 (1.77)	± 50 (1.95)
Measurement device		Glass scales (XY)/encoder (UVZ)	Glass scales (XY)/encoder (UVZ)
Minimum resolution	µm (µin)	0.1 (4)	0.1 (4)
Taper cutting			
Maximum taper angle	°/mm (in)	± 25/80 (3.15)	± 25/80 (3.15)
Wire drive system			
Wire guide diameter	mm	0.15/0.20/0.25/0.30	0.15/0.20/0.25/0.30
	in	0.006/0.008/0.010/0.012	0.006/0.008/0.010/0.012
Spool weight	kg (lbs)	25 (55)	25 (55)
Wire tension	N	3 ~ 30	3 ~ 30
Wire speed	mm/s (in/s)	30 ~ 330 (1.18 ~ 13)	30 ~ 330 (1.18 ~ 13)
Wire threading		Automatic (standard)	Automatic (standard)
Dielectric unit			
Capacity of clean water tank	l (gal)	200 (53)	230 (60.75)
Capacity of dirty water tank	l (gal)	600 (158.5)	970 (256)
Filter cartridge		2	2
Filter cartridge (Height/diameter)	mm (in)	450 x 340 (17.71 x 13.38)	450 x 340 (17.71 x 13.38)
Capacity of deionizing bottle	l (gal)	20 (5.3)	20 (5.3)
Generator			
Maximum current	A	35	35
Best roughness Ra	µm (µin)	< 0.25 (10)	< 0.25 (10)

* Width x depth x height ** Width x depth *** Option

CNC

Control system		Pentium Intel	Pentium Intel
Hard disc	GB	≥ 40	≥ 40
Display		15" LCD	15" LCD
Operating system		Windows	Windows
Controlled axes		5, among which 4 simultaneous	5, among which 4 simultaneous
Port		USB, MDI, LAN port	USB, MDI, LAN port
Power failure protection function		Yes	Yes
3D/2D graph check/scale/move function		Yes	Yes

Power supply

Standard power supply	V	3 x 380/3 x 400	3 x 380/3 x 400
Main frequency	Hz	50 or 60	50 or 60
Permissible fluctuation		± 10 %	± 10 %
Power supply consumption	kVA	9	9
Full load current	A	13.5	13.5

Air supply for wire threading

Air pressure	bar	6 ~ 9	6 ~ 9
Diameter of pipe	mm	6	6

General Data

For guaranteed accuracy	°C	20 ± 1	20 ± 1
For operation of the equipment	°C	15 ~ 30	15 ~ 30
Permissible relative humidity		40 % ~ 80 %	40 % ~ 80 %

Chiller specifications (Included in standard configuration)

Dimension *	mm (in)	450 x 550 x 1040 (17.71 x 19.68 x 40.95)
Cooling Capacity	kW	5
Power Supply	V	3 x 400 (50/60 Hz)
Rated Power	kW	2.5
Rated Current	A	7
Controlled Temperature Range	°C	15 ~ 50, Control Accuracy ± 1
Minimum Flow Rate	l/min (gal/min)	30 (7.92)
Ambient Temperature	°C	10 ~ 45, auto stop if temperature > 48

* Width x depth x height

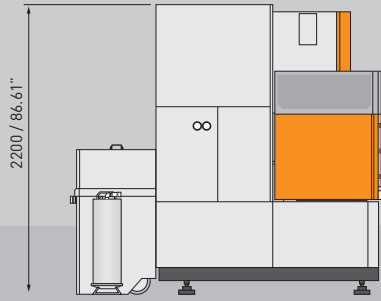
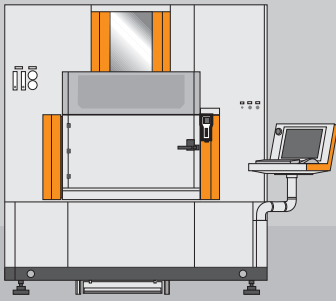

CUT 20 P

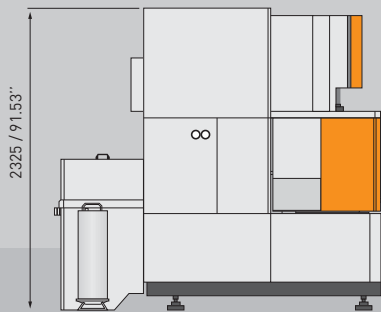
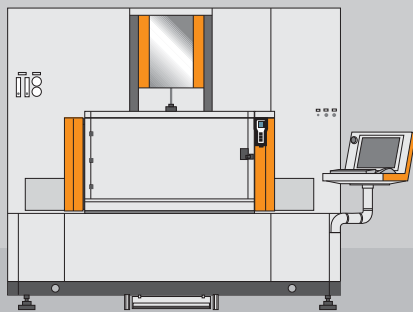
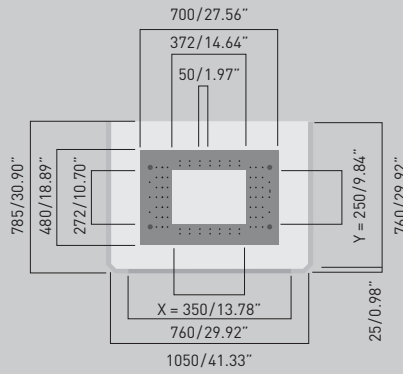
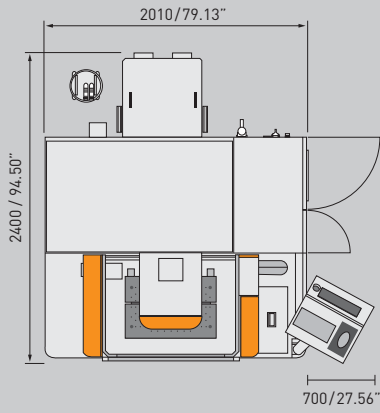

CUT 30 P

