

Technical data

MIKRON HSM 400 LP
MIKRON HSM 600 LP
MIKRON HSM 400U LP
MIKRON HSM 600U LP
MIKRON HSM 500 LP
MIKRON HSM 800 LP
Linear Performance

			MIKRON HSM 400 LP	MIKRON HSM 400U LP	MIKRON HSM 500 LP	MIKRON HSM 600 LP	MIKRON HSM 600U LP	MIKRON HSM 800 LP
--	--	--	----------------------	-----------------------	----------------------	----------------------	-----------------------	----------------------

Workarea

Longitudinal	X	mm	500	500	500	600	800	800
Lateral	Y	mm	450	240	450	600	600	600
Vertical	Z	mm	360	360	360	500	500	500
Swivelling axis		°	-	+110/-110	-	-	+ 30/-110°	-
Tilting axis		°	-	n x 360	-	-	n x 360°	-

Feed rate

Rapid traverse	X, Y	m / min	60	60	60	60	60	60
Rapid traverse	Z	m / min	60	60	60	60	60	60
Rapid traverse (Swivelling)		rpm	-	165	-	-	60	-
Rapid traverse (Turning)		rpm	-	250	-	-	150	-

Working spindle (40% ED, S6)

54'000 rpm, HSK-E32	kW / Nm	8.5/ 3.5	8.5/ 3.5	8.5/ 3.5	-	-	-
42'000 rpm, HSK-E40	kW / Nm	13.5/ 8.8	13.5/ 8.8	13.5/ 8.8	13.5/ 8.8	13.5/ 8.8	13.5/ 8.8
36'000 rpm, HSK-E50	kW / Nm	-	-	-	32 /20	32 /20	32 /20
30'000 rpm, HSK-E40	kW / Nm	13.5/ 8.8	13.5/ 8.8	13.5/ 8.8	13.5/ 8.8	13.5/ 8.8	13.5/ 8.8

Work table

Clamping surface	mm	in acc. Pallet	in acc. Pallet	550 x 450	900 x 600	in acc. Pallet	900 x 600
Max table load	kg	120	25	200	500	120	1000

Tool magazine

HSK-E32	piece	20/40	20/40	20/40	-	-	-
HSK-E40	piece	18/36/68/168/308	18/36/68/168/308	18/36/68	18/36/68/168/308	18/36/68/168/308	18/36/68/168/308
HSK-E50	piece	-	-	-	15/30/60/120/170/220	15/30/60/120/170/220	15/30/60/120/170/220

Automation

Pallet size / Number	- / piece	UPC/Dynafix / 7x	M.M. 156/18x	-	600 x 600/4x	UPC/Dynafix / 7x	800 x 600/4x
Pallet size / Number	- / piece	GPS 240/10x	ITS 148/20x	-	-	GPS 240/10x	-
Max. load	kg	80	25	-	500	80	800

Weight

Machine	kg	6'800	7'000	6'800	9'800	10'000	9'800
Pallet magazine	kg	1'200	1'200	-	1'800	1'200	1'800

Control unit

	Heidenhain	iTNC 530	iTNC 530	iTNC 530	iTNC 530	iTNC 530	iTNC 530
--	------------	----------	----------	----------	----------	----------	----------

smart machine www.gfac.com

**MIKRON HSM 400 LP
MIKRON HSM 400U LP
MIKRON HSM 500 LP**
Standard lift-up chip conveyor
and band filter unit

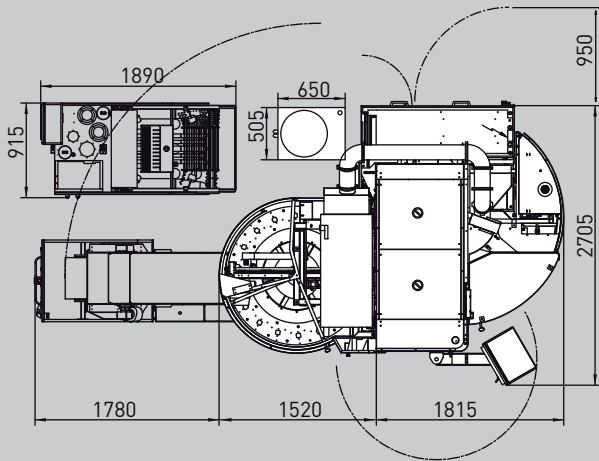
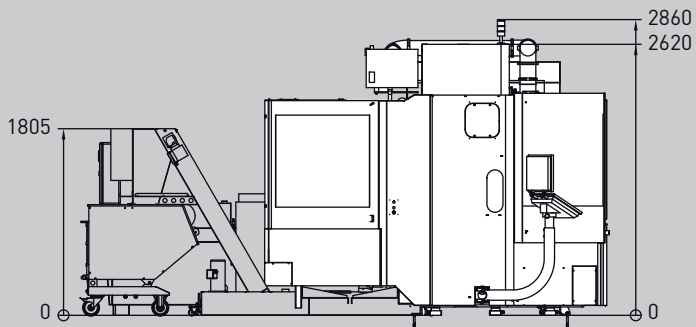

**MIKRON HSM 600 LP
MIKRON HSM 600U LP
MIKRON HSM 800 LP**
High performance lift-up chip conveyor
and band filter unit

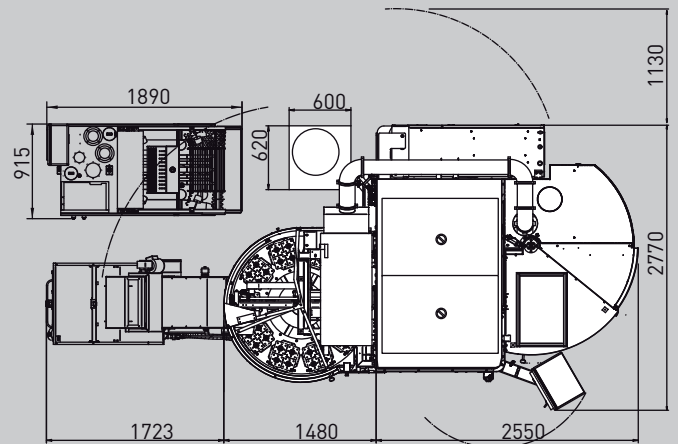
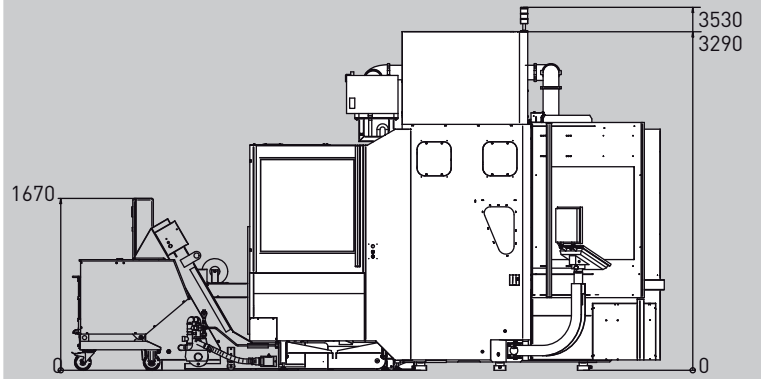

CE Our constructions are continuously adapted to meet the current requirements. Alterations can be made at any time. The information in this print is non-binding.

259 805 152