

PLANOMAT HP

Cutting edge technology for
surface and profile grinding



Key data

The PLANOMAT HP combines the know-how and tradition of more than 1,000 delivered machines. Its range of application extends from customized production solutions to universal grinding machines for individual component and small batch production.

The PLANOMAT HP is available in 6 sizes: from 400 x 800 mm to 600 x 2,000 mm.

Blohm Jung GmbH

Productivity, performance and precision – three attributes which users worldwide associate with surface and profile grinding machines from BLOHM and JUNG. Our machines have been in use worldwide for decades in widely varying fields of application and under very different conditions.

The experience gained from over 35,000 delivered machines is constantly incorporated into further developments and innovations, increasing our customers' production efficiency even further. The product portfolio of Blohm Jung GmbH extends from surface grinding machines through application-oriented universal machines to customer-oriented production machines. Our service and technology specialists support our customers throughout the entire lifecycle of the machine. From grinding tests through training and maintenance contracts to retrofits, we offer our customers prompt and personal advice.

In 2008 the two established brands BLOHM and JUNG merged under one roof. Blohm Jung GmbH has thus combined its extensive know-how and constantly enables new, higher standards in the area of precision, quality and cost efficiency. There are also many opportunities for tailoring production solutions to individual customer requirements.

As part of the UNITED GRINDING Group, Blohm Jung GmbH is represented internationally with offices in India, China, Russia and the USA. A further 40 sales and service agencies guarantee a worldwide presence and customer proximity. The company's main locations are the development and production facility in Hamburg and the service and technology center in Göppingen.

PLANOMAT HP

The PLANOMAT HP offers cutting edge technology for surface and profile grinding · The many different potential applications guarantee maximum flexibility for your production · The constantly maintained precision over a long lifetime allows the production of high quality workpieces

PLANOMAT HP - reliable, versatile, unique

Charakteristics

Dimensions

- 6 machine sizes with grinding ranges of 400 x 800 mm, 400 x 1,200 mm, 600 x 800 mm, 600 x 1,200 mm, 600 x 1,600 mm and 600 x 2,000 mm

Hardware

- Modular system
- High quality components comprising gray cast iron
- Thermal and vibration engineering characteristics optimized via finite element analysis
- Precision linear guideways
- High quality, ground re-circulating ball-screw drives

Software

- BLOHM EasyProfile control system
- Operation with high level of programming convenience
- Siemens 840D solution line with safety functions
- Programming with menu-guided grinding and dressing cycles
- Tailormade CNC control unit for tool and die making

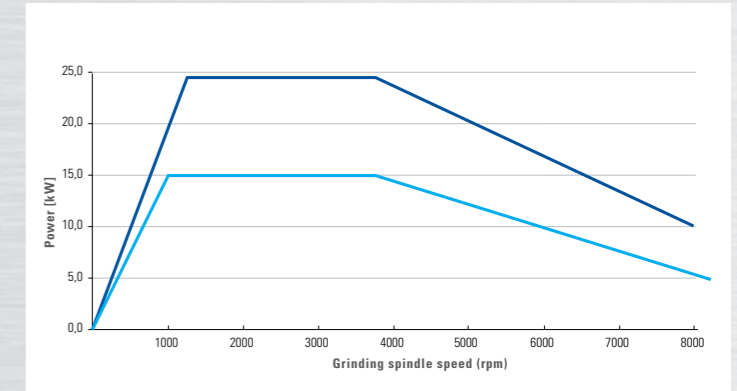

The grinding spindle drive has a capacity of 15 kW. A 24.5 kW drive is optionally available.

The PLANOMAT HP excels due to high feed and acceleration rates using high precision re-circulating ball screws and digital servo drives. Almost maintenance free linear guideways, linear glass measuring scales for Y- and Z-axis as well as powerful grinding spindle drives of 15 kW (opt. 24.5 kW) complete the future orientated concept.

Machine bed, column, table and wheel head of the PLANOMAT HP machines are made of cast iron. This provides high rigidity and dampening. Thanks to 3D-CAD and finite element analysis, we have further optimized the rigidity and weight of the machines. This design guarantees high precision and long life time.

The PLANOMAT HP series is available with the new EasyProfile control or with the CNC control Siemens 840D solution line.

Plug and play: a 3-point location (PLANOMAT HP 408 - 612) and the integrated electrical cabinet make it possible. Special foundations and electrical installations between machine and cabinet are not required.

For every need: whether as customer specific production solution or as a universal machine for single part and small batch production, the PLANOMAT HP offers both in 6 sizes.

Well-proven – the design principle

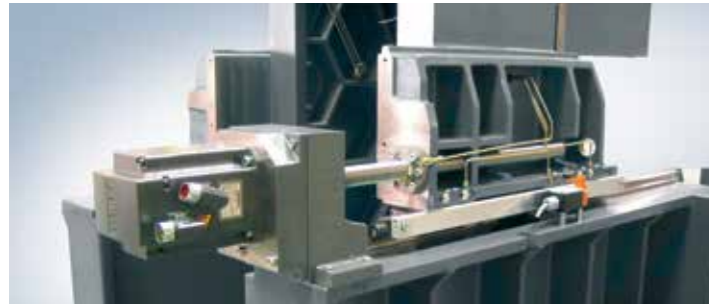

Z-axis, direct drive with linear glass scale



High-class, ground **re-circulating ballscrews** in all axes for silent operation



Precision guideways for stick-slip free motion



Cartridge type spindle with short taper for repeatable grinding wheel positioning

Dressing attachments

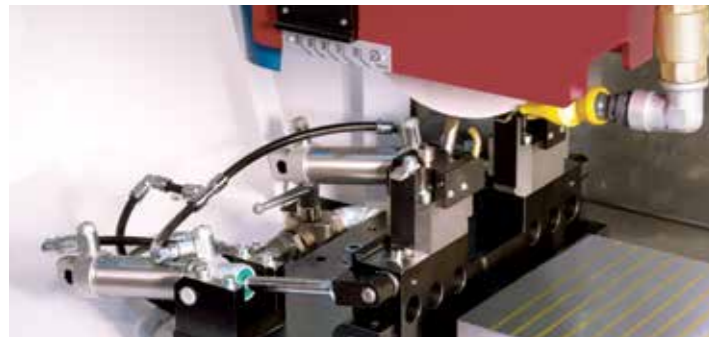

Tilting dressing attachment for circumferential, face and profile dressing. The attachment is pneumatically actuated and is tilting down to avoid collision with the grinding wheel and wheel guard during the grinding cycle.



Table mounted dresser type PEA-TL200S for diamond rolls up to a width of 200 mm or for contour dressing with two universal diamond dressing disks and a rough dressing disk.

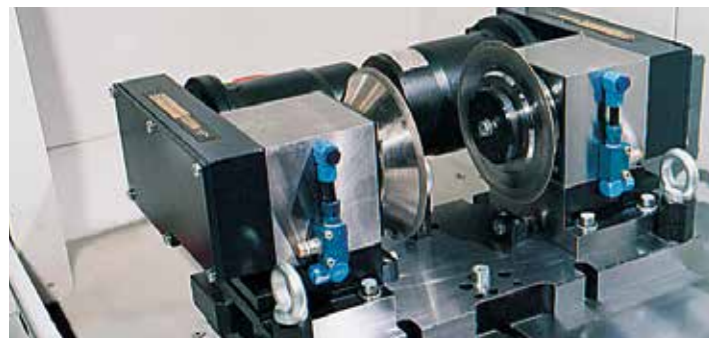
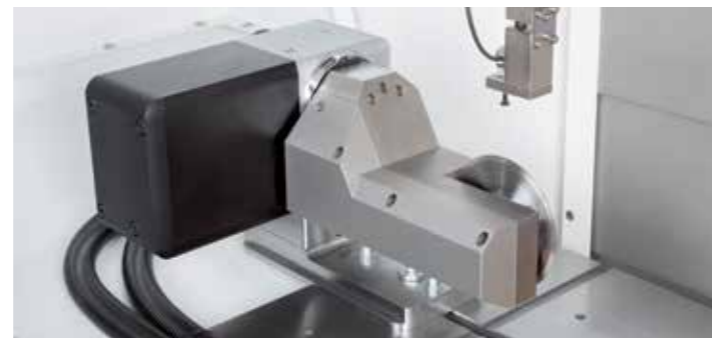

Table mounted dresser type PA-TLR40 for universal diamond dressing disks for contour dressing. The roll arbors can be tilted by 0.3 mm for calibrating of grinding wheels.



Articulating dressing attachment PA-T130 continuous path controlled dressing by means of using the machine axes and the CNC controlled articulating axis of the dresser. Electronic measuring device with stand, probe and calibration ball.

Accessories for the process optimized production



NC indexing table, 1 or 2 axis, indexing accuracies up to $\pm 1''$

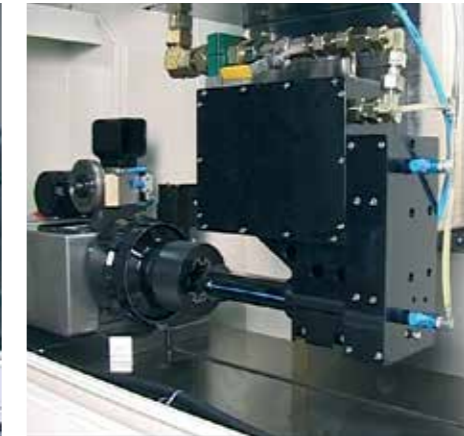

Horizontal internal grinding spindle, for grinding wheel diameters of 25 ... 70 mm, up to 45,000 rpm



Horizontal internal grinding spindle, for grinding wheel diameters of 25 ... 70 mm, up to 45,000 rpm



Measuring probe, pneumatically retracting from measuring position, measuring accuracy $\pm 1 \mu\text{m}$



Vertical grinding spindle, on sliding bracket, 5 kW, max. 30,000 rpm

Additional accessories:

- Electro-permanent magnetic chucks
- Automatic balancing systems
- Coolant filtration units
- Coolant mist exhaust units
- Accessory package for the use of pure grinding oil
- Acoustic sensors
- Special horizontal or vertical grinding spindles

RazorTec®



New way of grinding wheel cleaning, with newly developed nozzle positioner, 30% less grinding wheel wear, 30-40 bar nozzle pressure

Operation made easy – the BLOHM EasyProfile control



The BLOHM EasyProfile control revolutionized the operation. It is the result of close cooperation between the Blohm Jung GmbH and Siemens and combines the proven Siemens 840D solution line hardware with the innovative user interface developed by BLOHM. The clear, menu-driven operation via a color touch screen is intuitive and simple.

You utilize the performance of our PLANOMAT HP machines optimally with the BLOHM EasyProfile control and increase your productivity sustainable.

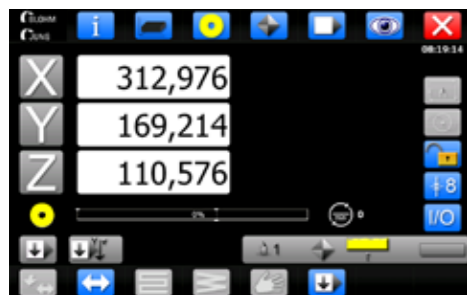

Standard screen



Simple definition of workpiece dimensions



3 layer automatic grinding cycle: roughing, semi-finishing, finishing, spark-out with integrated dressing cycles. Only a few parameters are required to complete the cycle.

The scope of delivery includes the following canned cycles:

- Reciprocate plunge grinding
- Surface grinding with intermittent or continuous cross feed
- Input of a stock amount or finish dimension
- 3 layer automatic grinding cycle with ECO-roughing function
- Plunge or surface grinding with manual infeed
- Creep feed grinding cycle
- Recessing of grinding wheel flanks

Dressing cycles are started automatically by the program, via stroke counter or manually via push button.

Additionally, BLOHM's new dressing system ADC (Adaptive Dressing Control) is available. The dressing cycle is started automatically when the power consumption of the grinding spindle drive increases due to the loading of the grinding wheel reaching a pre-selected value.

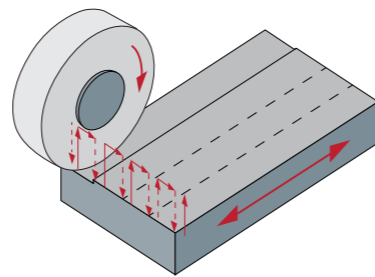

ECO-roughing cycle: guaranteed time savings through optimized strokes

Increase your productivity – with EasyProfile-upgrades

Software package 1 – Additional grinding cycles

This software package includes grinding cycles for automatic step grinding, rotary table surface grinding and automatic gap control.

The **multi-step grinding program** permits grinding of up to 10 different grinding planes in one set-up. The Y- and Z-starting position, working parameters for roughing, finishing, dressing, re-positioning in Y-direction for each plane are individually programmable.

Grinding program for rotary table – surface grinding by means of oscillation of the Z-axis with positioned X-axis and automatic infeed in Y-direction.

Automatic gap control to reduce air-grinding time for work pieces with varying stock. The air gap between grinding wheel and workpiece will be eliminated by a high infeed. When the grinding wheel touches the workpiece the rapid infeed is changed to normal grinding infeed.

Software package 2 – Profile dressing and profile grinding

Expand the scope of EasyProfile control to permit the profile grinding applications. 8 different dressing contours are available which are easily defined by parametric inputs via the touch screen. If the edited values do not generate a continuous contour it is recognized by the control and an error message "contour error" is displayed. The grinding wheel profile will be generated by means of continuous path controlled dressing including rapid layer by layer pre-profiling cycle. Dressing of the wheel takes place by table mounted dressing attachments.



Selection of wheel contour

Software package 3 – Face grinding and calibrating

Face grinding: grinding of vertical surfaces by means of reciprocate face grinding. Infeed takes place at reversal point. According to the location of the surface the front or rear wheel flank will be used.

Calibrating: initial and subsequent calibrating of grinding wheel flanks with diamond blades or calibrating rolls.

Software package 4 - Grinding wheel management

Short change overtimes can be achieved by grinding wheel management for a maximum of 24 wheels. All process relevant grinding wheel data can be stored in the control before the wheel is taken off the machine. The wheel marked with name/number is stored outside the machine. Once

the wheel is remounted, the wheel identification is entered into the wheel management of the control and the stored data, i.e. actual wheel diameter, wheel width and profile definition are activated and displayed. The machine is immediately available for re-profiling of the grinding wheel.

Key advantages

- Touch-screen TFT-color display
- Optimal: intuitive operation and comfortable programming of grinding and dressing cycles
- No NC-programming knowledge required
- Ease of machine set-up with portable control unit
- Quick adaptation of dressing and grinding parameter due to graphical support
- Productivity increasing software upgrades

Tailor-made for tool and die making – the CNC control unit for individual parts and small batches

CNC control – comfortable solution for profile and contour grinding production applications

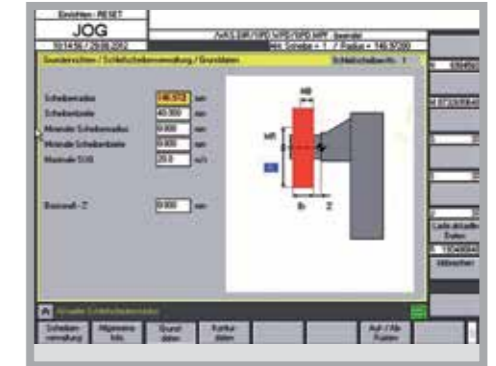
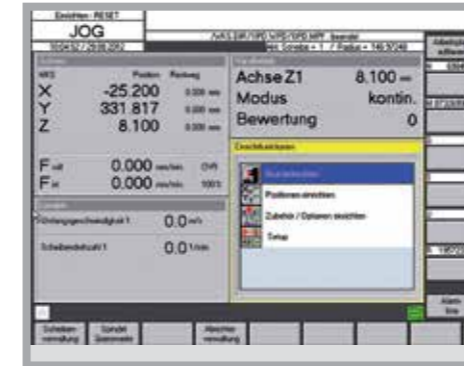

Standard screen

Preparation of grinding and dressing programs as well as file management

Management of up to 100 grinding wheels and 30 dressing tools

Basic screen

Program editor

Grinding wheel data

The PLANOMAT HP CNC machine control is a combination of the proven Siemens 840D solution line and program cycles especially developed for the tool and die industry by BLOHM. This combination makes the PLANOMAT HP specialist to solve difficult grinding tasks economically and flexibly. The typical requirements, such as “quick start reciprocate grinding programs” are already integrated. Program sequences can be quickly and easily adapted to the needs of your grinding application.

Efficient operation is ensured by conversational menu with graphical operator guidance and the pre-programmed keys (soft keys), e.g. for quick positioning, for moving to the loading, wheel change or dressing position. If needed you can simply switch to the conventional grinding mode.

Programming while the machine is in operation and the program input and output via the integrated USB interface is also possible. Program

sequences can be interrupted at any point and the machine will automatically retract and get back to the last position, e.g. inspection of the part. Operated by keyboard, mouse or through the portable control unit.

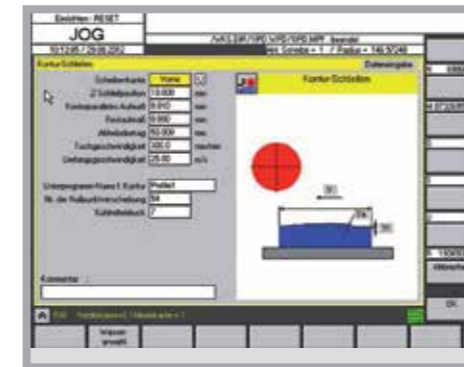

Workpiece parameter

Key advantages

- User friendly with comfortable programming functions
- Simple set-up of machine and parameter, also with the portable control unit
- Quick adaptation of grinding and dressing cycles with graphical support
- Praxis orientated software upgrades to increase the productivity

Productivity-enhancing software extensions

GripsProfile:

- 13 standard contours
- Import of dxf-files
- Contour program generation
- Simulation

Optional grinding cycles:

- Roughing operation
- Plunge grinding
- Contour grinding Z/Y and X/Y
- Z-axis cross positioning
- Face grinding
- Punch grinding with base

Optional programs:

- Machine-warm-up / switch-off program
- Program linkage
- GripsProfile
- CAD-module for GripsProfile
- GripsProfile light
- Tool management

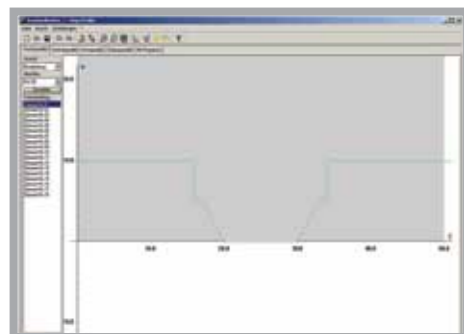

We are looking forward to informing you about our productivity-enhancing software upgrades.

BLOHM offers for the PLANOMAT HP a production version of the CNC control Siemens 840D solution line with PCU 50 which is especially adapted for the needs of profile and contour grinding applications in large batch and mass production. The BLOHM user interface with keyboard and graphical operator guidance simplifies the programming. A variety of parametric grinding and dressing cycles allow quick generation of the main programs. Individual cycles assist to create a very flexible,

sequential program structure and time-optimized program sequence. Using the optional software GripsProfile ensures that even complex grinding and dressing programs are created with ease. The functions for grinding wheel balancing and process monitoring through acoustic touch sensor are optionally available. The control system also manages the grinding wheels and dressers.

In addition the CNC control includes the integration of additional functions and peripheral devices such as:

- Frequency controlled coolant pumps and automatic coolant nozzles trace systems
- Automatic balancing system
- NC-indexing table
- Measuring probe
- Tool management
- Acoustic sensors

PLANOMAT HP – productive manufacturing solutions

Machine building



Hirth-coupling

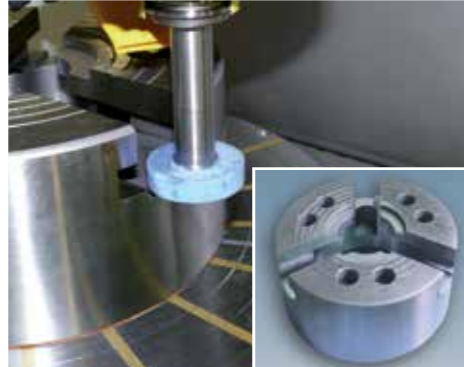

Three jaw chuck

Tool and die industry

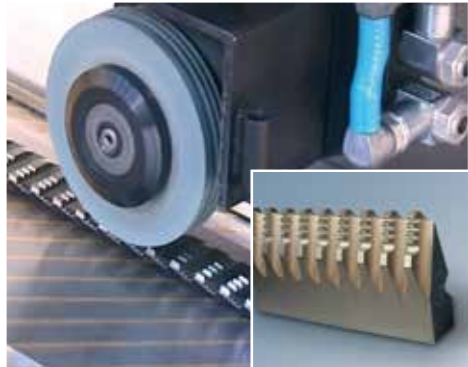

Broach tool



Press-break tool

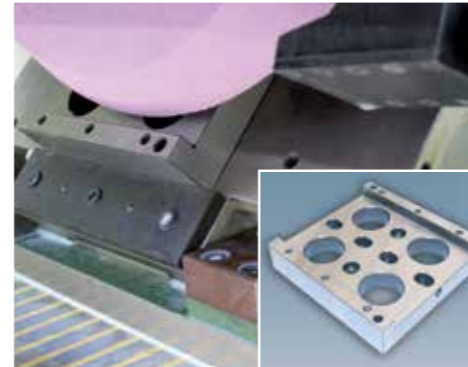

Tool holder

Bearing industry

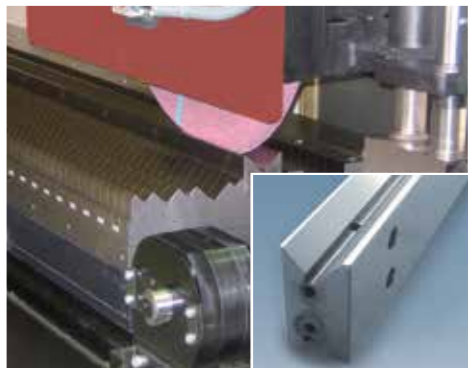

Guideway

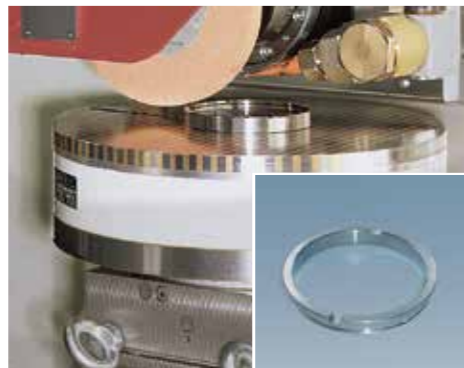

Grinding of anti-rotation slots



Linear guideway

Turbine industry

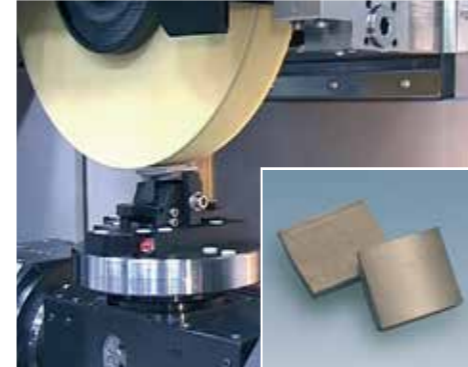

Five-sided grinding of shroud components

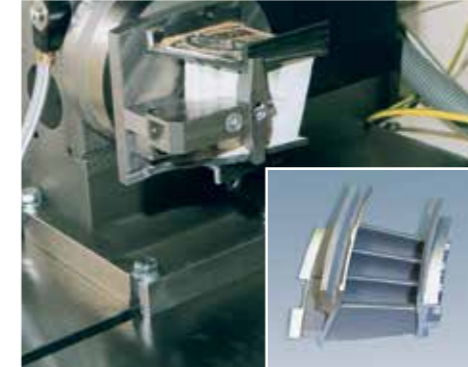

Vane and blade

Pump industry

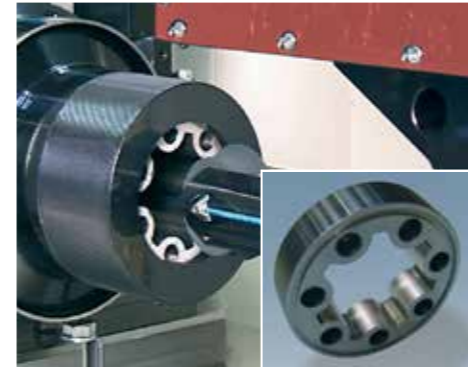

Inner-profile of hydraulic pump rotor

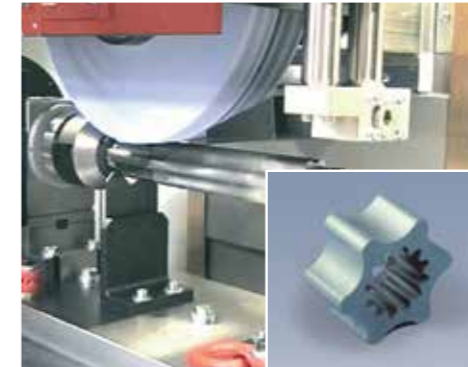

Outer-profile of hydraulic pump rotor

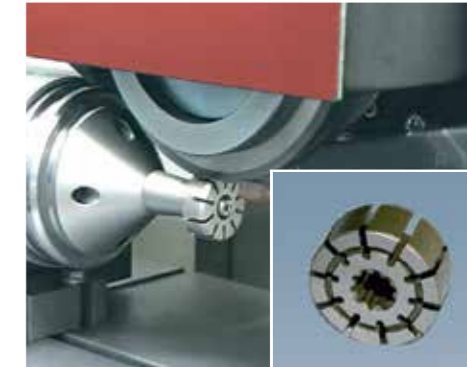

Slots of pump rotor

Automotive industry and suppliers



Fin disc for radiators



Steering rack piston nut

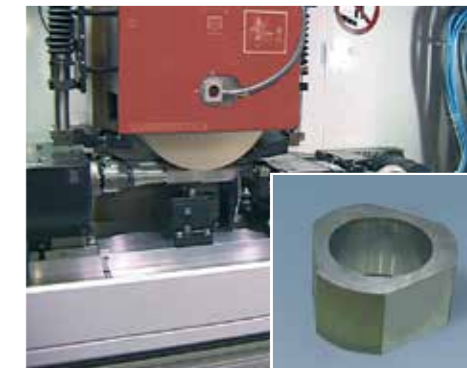

Roller for injection-pump

Customer Care

BLOHM and JUNG surface and profile grinding machines should fulfill the customers requirements for as long as possible, work cost-effectively, function reliably and be available at all times. From "start up" through to "retrofit" – our Customer Care is there for you throughout the working life of your machine. 6 professional helplines and more than 25 service technicians are available in your area, wherever you are in the world.

- We will provide you with fast, uncomplicated support.
- We will help to increase your productivity.
- We work professionally, reliably and transparently.
- We will provide a professional solution to your problems.



Start up
Commissioning
Warranty extension



Qualification
Training
Production support



Prevention
Maintenance
Inspection



Service
Customer service
Customer consultation
HelpLine
Remote service

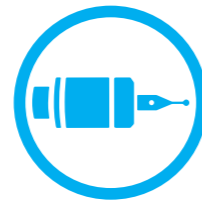

Material
Spare parts
Replacement parts
Accessories



Rebuilt
Machine overhaul
Assembly overhaul



Retrofit
Modifications
Retrofits
Machine trade-in

Technical data

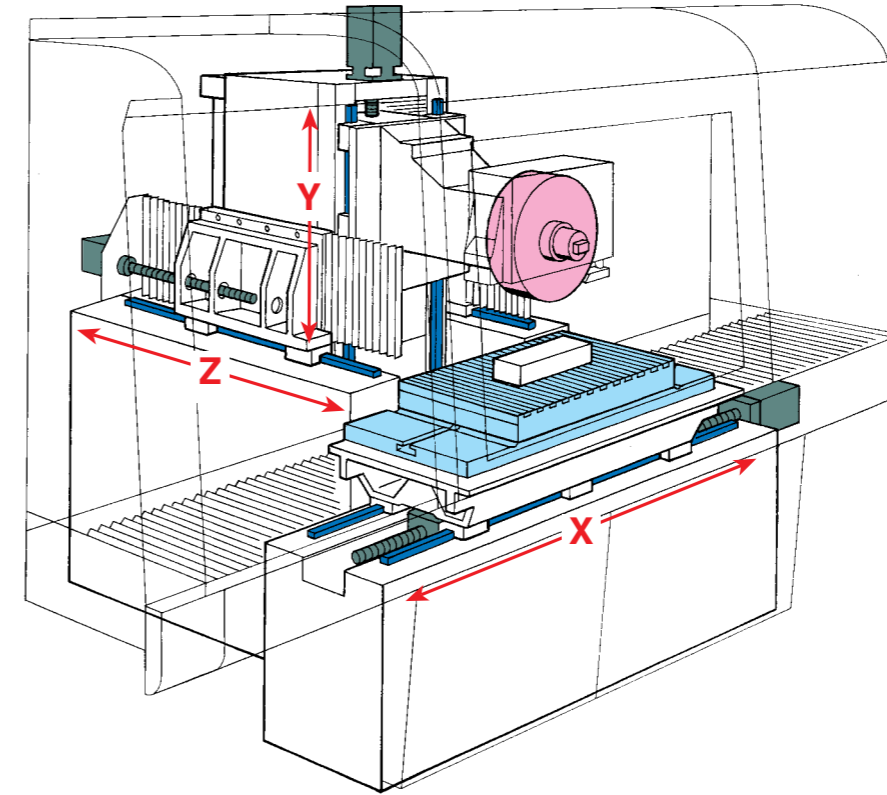

PLANOMAT HP		408	412	608	612	616	620
Grinding range	mm	400 x 800	400 x 1,200	600 x 800	600 x 1,200	600 x 1,600	600 x 2,000
Magnetic chuck	mm	400 x 1,200	400 x 1,600	600 x 1,200	600 x 1,600	600 x 2,000	600 x 2,400
Distance table to spindle center	mm	150 ... 700 (optional 950)					
X-axis, longitudinal travel, max.	mm	900	1,300	900	1,300	1,700	2,100
Feed rate	mm/min	30 ... 40,000					
Y-axis, wheel head vertical travel, max.	mm	550 (optional 800)					
Feed rate	mm/min	4 ... 6,000					
Z-axis, column cross travel, max.	mm	360	360	560	560	560	560
Feed rate	mm/min	4 ... 6,000					
Grinding spindle drive, variable speed, AC-motor	kW/rpm	15/1,000 (optional 24.5/1,250)					
Grinding wheel (d x w x bore).	mm	400 x 30 ... 100 x 127					
Dimensions width	mm	3,470	4,470	3,470	4,470	5,450	5,450
depth	mm	2,200	2,200	2,600	2,600	2,600	2,600
height	mm	2,600	2,600	2,600	2,600	2,900	2,900
Weight, incl. electrical cabinet	kg	3,900	4,600	4,900	5,400	7,000	7,800

We reserve the right to make technical changes



Blohm Jung GmbH

Location Hamburg

Kurt-A.-Körper-Chaussee 63-71
D-21033 Hamburg
Phone +49 40 72 50 02
Fax +49 40 72 50 32 87
sales-hh@blohmjung.com

Location Göppingen

Jahnstraße 80-82
D-73037 Göppingen
Phone +49 7161 612 0
Fax +49 7161 612 170
sales-gp@blohmjung.com

www.blohmjung.com

BLUECOMPETENCE

Alliance Member

Partner of the Engineering Industry
Sustainability Initiative

